



Product Specifications SE25 - 110mm tunnel

NEW



Leading boat builders all over the world choose Side-Power for performance, reliability, ease of installation and unrivalled safety features. This commitment to quality and product development has made the Side-Power range of thrusters the benchmark in the industry.



Declaration of Conformity

We, Sleipner Motor AS hereby Declare that following Side-Power DC thruster products complies with the EC Directives and Standards:

Directive 2013/53/EU - Recreational Craft Directive
2006/42/EC - Machinery Safety
Directive 2014/30/EU - Electromagnetic Compatibility

SE series	Side-Power Electric Tunnel Thruster	25-210kg thrust ON/OFF
-----------	-------------------------------------	------------------------

FREDRIKSTAD, 21th of January 2017

Arne K Skauen
Managing Director, Sleipner Motor AS

Technical and safety specifications

- Motor:** Custom made reversible DC-motor.
- Gearhouse:** Seawater resistant bronze. Ball bearing at propeller shaft and combination of ball bearing and slide bearing at driveshaft. Pre filled and sealed for life.
- Motor bracket:** Glass fibre reinforced composite material. Brass thread inserts.
- Tunnel:** Cross spun with rowing G.R.P tunnel
Steel and aluminium tunnels are available on request.
- Propeller:** 5- blade skewback design "Q-prop" propeller, reinforced composite.
- Batteries:** Minimum recommended battery capacity (cold crank capacity by DIN/SAE standard)
See table.
- Max. use:** S2 = 3 min. or approx. 7-10% within a limited time frame.
- Safety:** Electronic time-lapse device protects against sudden change of drive direction. Electric thermal cut-off switch in electrical motor protects against over heating (auto reset when electrical motor cools down). Flexible coupling between electrical motor and driveshaft protects electrical motor and gear system if propeller gets jammed.

If original Side-Power panel is used, the panel shuts off automatically 6-9 minutes after last use.

Integrated microprocessor monitors solenoids, reducing wear and risk of solenoid lock-in. Auto-stop of thruster in case of accidental solenoid lock-in or if run signal is continuous for more than 3 minutes.



Confidence by Control

SIDE-POWER.com

Skippers Depot
www.skippersdepot.com
Cutler Bay, Florida
1-800-270-3797

Version 1_0_0_2017



NEW



Specifications and performance data

- Actual performances will vary for each installation depending on many factors.
- Specifications shown here are based on a thruster installed at a depth equal to one tunnel diameter and with DC electric power at thruster as shown.

SE / Serie*

SE 25/110 S

Thrust at 12V* (kg • lbs)	30 • 66
Thrust at 10.5V* (kg • lbs)	25 • 55
Typical boat size (ft • m)	> - 24' • > - 7
Tunnel I.D (mm • in)	110 • 4.33"
Propulsion system	Single
Power at 10.5V* (kw • Hp)	1.5 • 2
For DC system (V)	12
Weight (kg • lbs)	9.5 • 21
Rec. CCA (CCA** 12/24V)	200/380
Art.nr. 12V	SE25/110S-12V



Battery and cable recommendations

SE, - series

- All cable lengths are the total of both - and + cables.
- Battery size is stated as minimum cold crank capacity, not Ah.
- Use slow fuse rated to hold stated Amp-Draw for min. 5 minutes.

Minimum and recommended cable dimensions can be identical due to safety margins and cable heat considerations for short cable lengths.

* Minimum or recommended cable cross section in mm²

Model	Voltage	Nominal current draw	Min. battery CCA	Rec. fuse		<7m total + & -		7-14m total + & -		15-21m total + & -		22-28m total + & -		28-35m total + & -		36-45m total + & -	
						Min.	Rec.	Min.	Rec.	Min.	Rec.	Min.	Rec.	Min.	Rec.	Min.	Rec.
SE25/110S	12 V	200 A	DIN: 200 SAE:380	ANL 150	mm2 AWG	35	35	50	50	70	70	95	95	95	120	2x70	2x70
						1	1	1/0	1/0	2/0	2/0	3/0	3/0	3/0	4/0	2x2/0	2x 2/0



Measurements SE Series

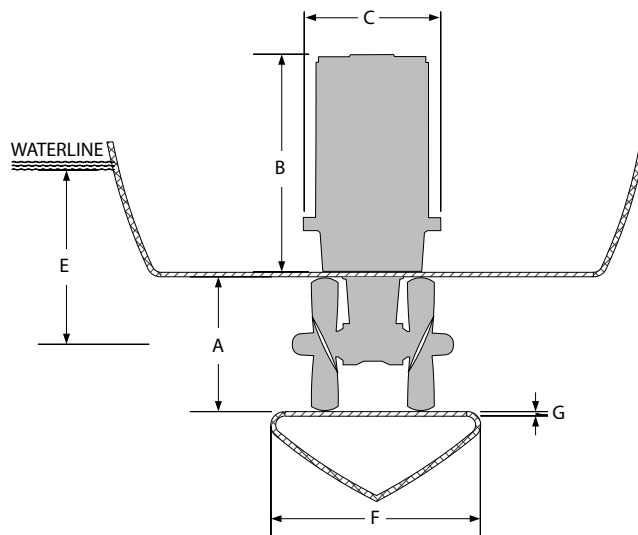
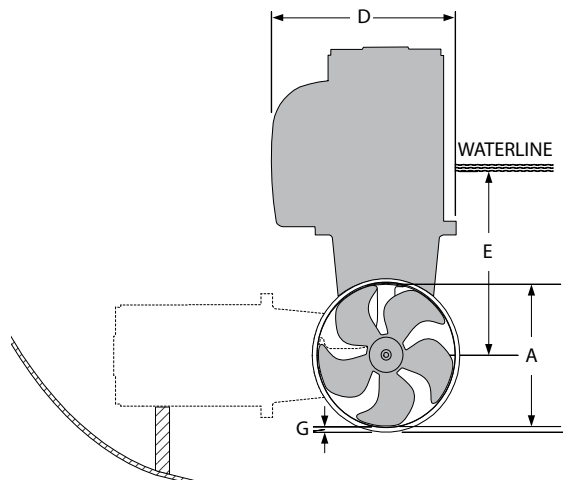

Thruster
(mm)

	A	B	C	D	E_{min}	F	F_{anbefalt}	G_{min}	G_{max}
SE25/110S	110	247	155	177	110	92	184	4	6





Maintenance

- DC motor: See User and Installation manuals for each model for more information.

Material specifications

- DC Motor: There are no hazardous materials in this product, ref material declaration.

Health and Safety

- Gearleg and DC motor: The Gearleg is shipped with gear oil - precautionary measures must be taken . The gearleg and DC Motor is very powerful and precautionary measures must be taken considering rotating propeller and electrical installation. Gear oil is flameable and and gasses from a fire is generally toxic.
- See Installation and User manual for more information.

*This document may contain typographical errors and changes,
to which Sleipner Motor assumes no responsibility.*

Skippers Depot
www.skippersdepot.com
Cutler Bay , Florida
1-800-270-3797



Sleipner Motor AS
P.O. Box 519,
N-1612 Fredrikstad, Norway
www.side-power.com



Confidence by Control

SIDE-POWER.com