

# Seafari Mini

The Seafari Mini is the perfect solution for boats with little space to spare. With the largest production capacity for it's size, you can be sure to have plenty of fresh water, without wasting precious storage or engine room space.

**Max Production:**  
750 Gal (2,839 Lit) / day\*

## Benefits

- Fits into small and complex spaces.
- DC option for the Mini 170 model.
- Lightweight - models range from 70 to 130 lbs.



Photograph courtesy of Riviera Yachts

\*Highest capacity model (Mini 750)



WARNING: This product can expose you to chemicals including Di(2-ethylhexyl)phthalate (DEHP), which is known to the State of California to cause cancer and birth defects or other reproductive harm. For more information go to [www.P65Warnings.ca.gov](http://www.P65Warnings.ca.gov).



Mini - compact



Mini - modular

# Seafari Mini - Specifications | Dimensions

Model Number	Per 24 Hours - Gal / Lit	Per Hour - Gal/ Lit	Weight
Mini 170	170 / 645	7/ 26	70 lbs / 32 kg
Mini 350	350 / 1,325	15 / 55	89 lbs / 40.4 kg
Mini 550	550 / 2,080	23 / 87	125 lbs / 57 kg
Mini 750	750 / 2,839	31 / 118	130 lbs / 59 kg

  

Electrical	Phase	Pump Motor	Voltage	Hz	H.P.	Running Amps	Start Up Amps
Mini 170	N/A	HP	12 / 24	N/A	0.33	27/13.4	90/45
Mini 170	Single	HP	110 / 230	50 // 60	0.33	6.6/3.3//5.2/2.6	26/13
Mini 350	Single	HP	110 / 230	60	1	12.8/6.4	39/20
Mini 350	Single	HP	110 / 230	50	1	12.4/6.2	37/19
Mini 550 / 750	Single	HP	110/220//115/230	50/60	1.75//2.1	18.9/9.4//18.2/9.1	57/28
Mini 550 / 750	Single	Booster	110 / 220	50/60	0.5	9.4/4.7-7.4/3.7	28/14

## MINI 170 - Compact

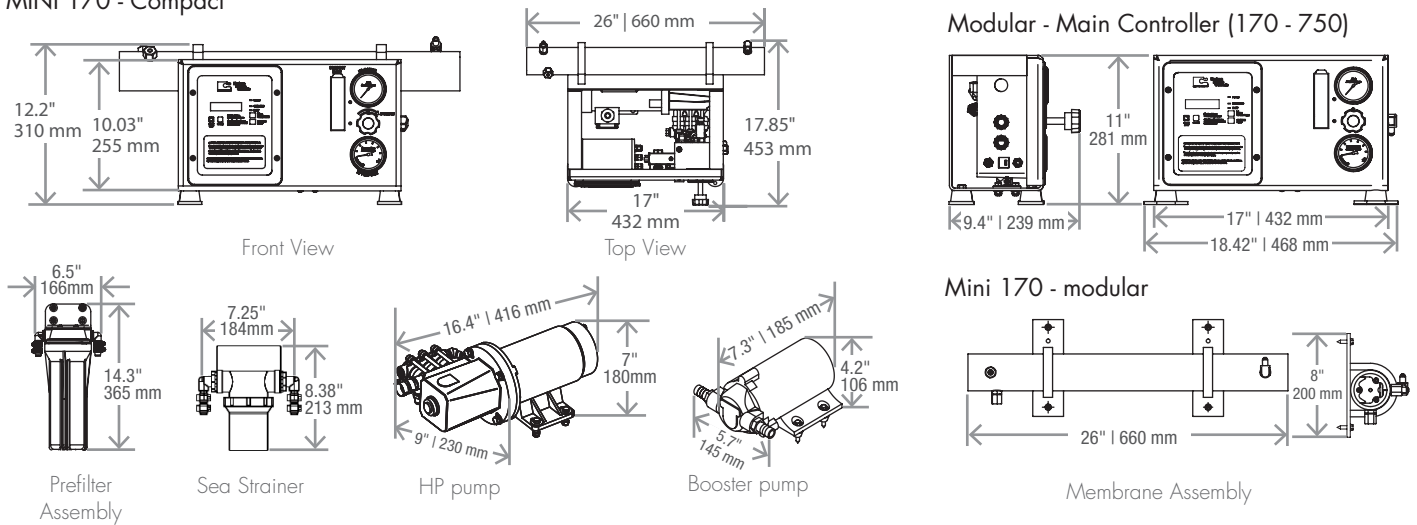

## MINI 350 | 550 | 750 - Compact

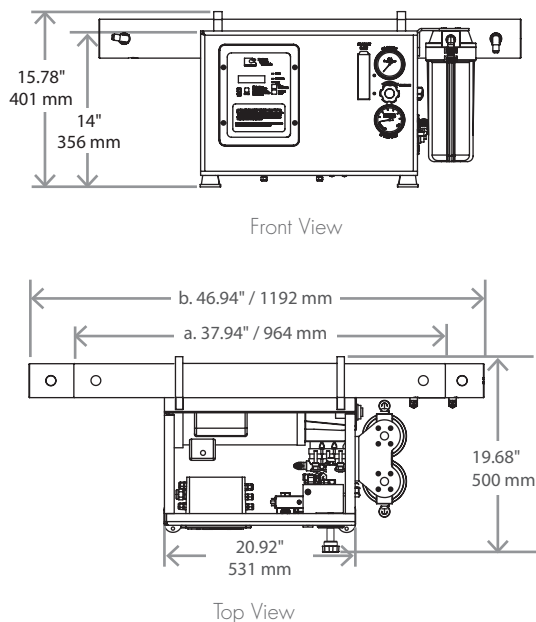

## MINI 350 | 550 | 750 - Modular

